

Self-propelled electric battery roller type seeder

JPEV-3

Instruction Manual

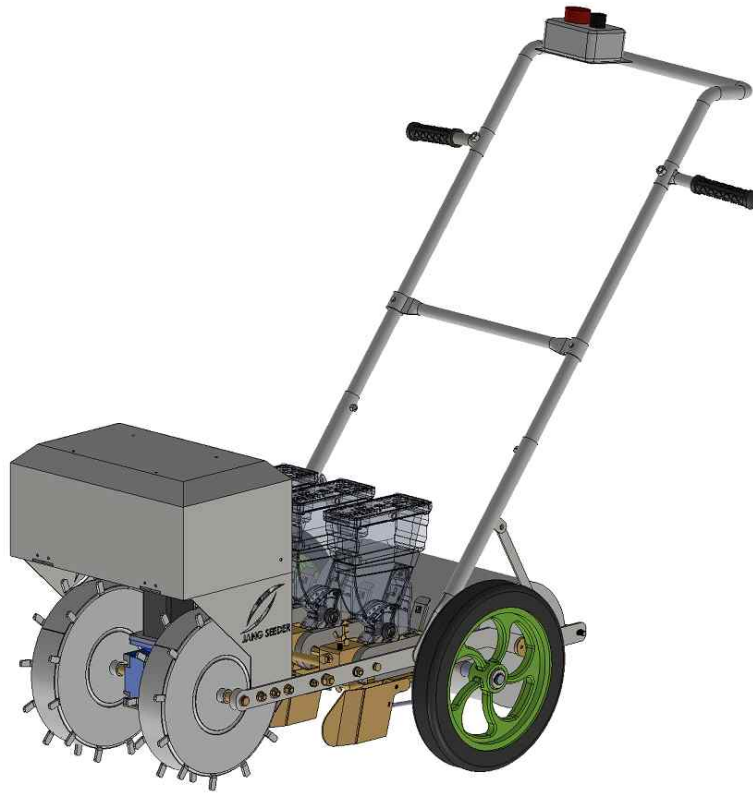

2004, Danjae-ro, Nangseong-myeon, Sangdang-gu, Cheongju-si,
Chungcheongbuk-do, Korea.

TEL : 82-(0)43-298-0076 FAX : 82-(0)43-297-0076 Website www.jangauto.com

Contents

1.	Product specification -----	03
2.	The name of each parts -----	04
3.	How to use the seeder -----	06
4.	How to adjust the spot seeding spacing -----	11
5.	Seeder operation tips -----	12
6.	Worker regulation -----	14
7.	Clothes, protect equipment wearing and protection device -----	16
8.	Compliance with the scope of machine and parts after operating -----	17
9.	Precautions of third parties -----	18
10.	Contents for material used. such as battery ----	19
11.	User's Guide -----	20
12.	Parts list -----	22

We appreciate your purchasing our seeder. Please carefully read instructions first before you actually operate our battery seeder. This manual includes cautions and how to operate our seeder safely. After reading it, be sure to keep this manual near the seeder.

1 Production Specification

Item	Self-propelled battery type seeder
Model Name	JPEV-3
Row number and Seeding type	3 rows, Spot Seeding Type
Length(mm)	1,227
Width(mm)	754
Height(mm)	957
Inter row (Spacing)	The adjustment method of inter row spacing between hopper block
Soil covering plate width(mm)	39mm and 70mm available
Driving roller & suppressing roller width (mm)	56(Driving roller)*2pcs, 360(Suppressing roller)
Weight (kg)	28.98(Bare frame), 31.38(built in battery)
Battery (Rated Power, Manufacturer)	Li-ion 2pcs (Maximum 4pcs applicable), Rated Power: 18V, 5.0Ah, 90Wh, Producer: MAKITA
Hopper Capacity	1ℓ/row (Option : Sub-hopper capacity2ℓ)
Feeding method	Seeding toll without static electricity / The seeding roll replacement method for rotation and for suitable seeds
Driving method	Driven by a driving roller mounted on a battery and motor
Power transmission method	Driven by battery and motor type
Spot seeding spacing	The sprocket exchange method (11 steps)
Seeding Depth	Depth adjustment : Maximum 40mm
Applicable seeds	Radish, spinach, bok choy, mugwort, carrots, green onions, coated seeds, etc (various seeds available by exchanging seed rolls)

2 The Name of each parts

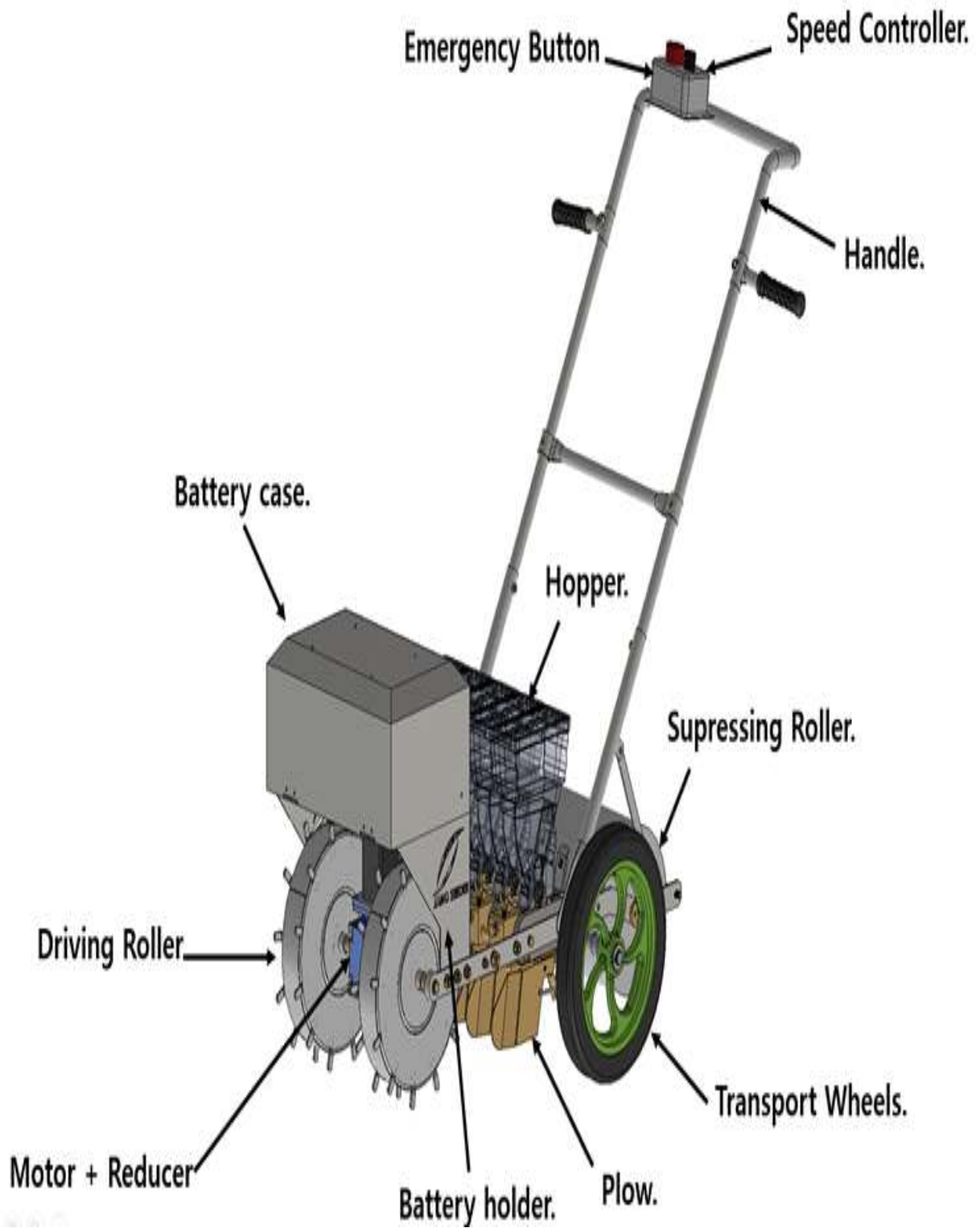

[Photo 1 – Name of Parts]

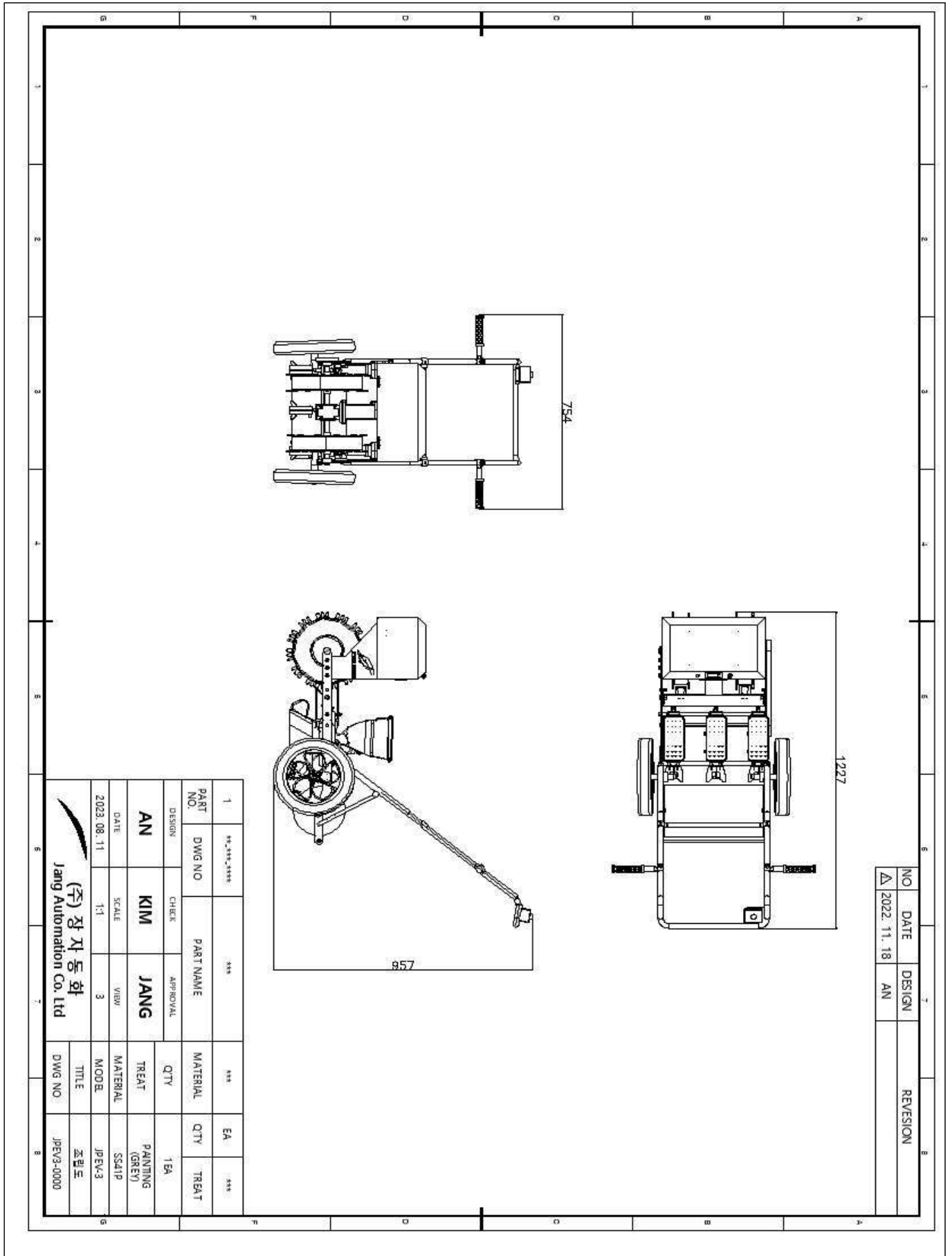

[Photo 2 – Assembly drawing and parts composition and layout]

3 How to use the seeder

1. Hopper (Seeds Feeding Part) usage and name of each parts

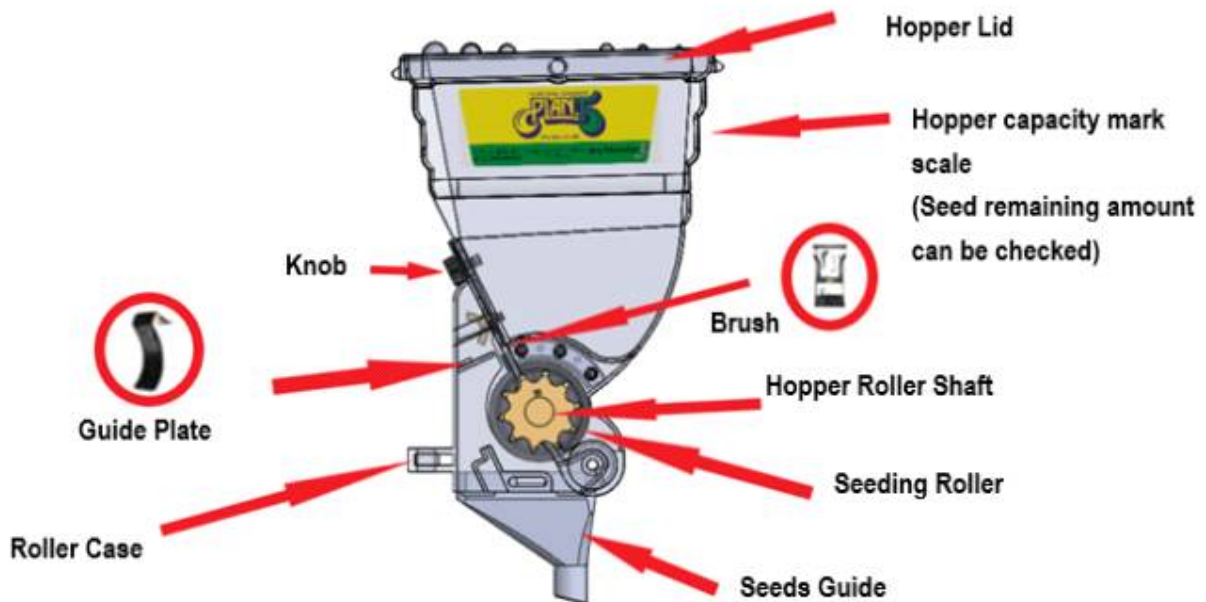

2. Inspection before work

- ① Check whether the bolts and nuts of each part are loose or missing.
- ② Apply oil to rotating parts other than the seeding roller and check that they move smoothly.
- ③ Seeds must be selected to prevent contamination of other foreign substances such as stones or metals from entering the seeds.
- ④ Check occasionally to see if the seeds are distributed and feed evenly.
- ⑤ Brushes and guide plates are consumables, so check them occasionally.
(If it is worn, it must be exchanged for a new one.)
- ⑥ Check the seeding roller occasionally to see if it is clogged with foreign substances, pesticides, coating debris, etc.
- ⑦ For seeding covered pavement, carefully crush the soil and finish it evenly.
- ⑧ If the work speed is too fast, precision decreased.
The seeding speed is 0.5~0.7m/sec.
- ⑨ If possible, do not soak seeds in water. Never wet coated seeds.
- ⑩ When disassembling the hopper, be careful not to allow dirt, etc. to enter the roller clutch part of the roller shaft.

3. Adjustment of hopper (seed dispensing part)

- ① How to remove the hopper (seed feeding unit)

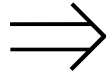

After lightly pressing the part (grip) where the hopper is inserted, flip the hopper to remove it, and insert the front part and press the back part to lightly insert it.

► One-touch attachment and detachment

- ② How to attach a guide plate



Attach the guide plate so that there is a small gap between it and the seeding roll near the brush. When using row seeding (line seeding), remove the guide plate and Please use it.

- ③ Brush attachment method (gap from roller)

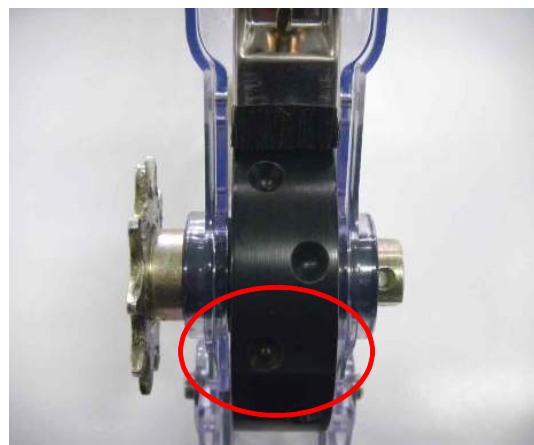

As a standard, the brush is in light contact with the seeding roll.

(If the brush is removed, the seeding amount will increase, and if it is too attached, it will wear out faster.)

④ How to replace seeding roller

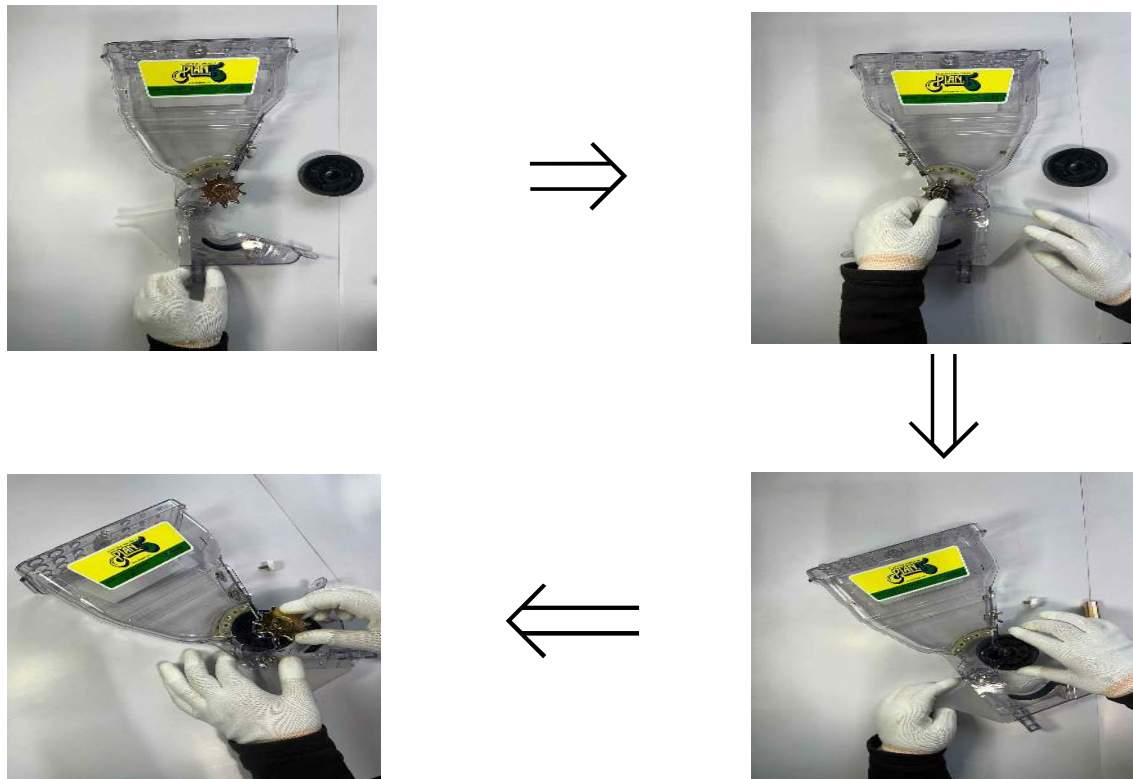

After removing the hopper, remove the knob to separate the roller case of the hopper, remove the R pin inserted at the end of the hopper shaft, and remove it by holding the sprocket. At this time, store the separated seeding roller carefully, replace it with the desired size, and assemble in reverse order.

4. Hopper Lid Description

Sprinkle a small amount of seed on the lid, rub it horizontally, and select the groove size that contains the desired amount. The number in the roller name is the number of holes.

Seeding roll selection by hopper lid

After pouring a small amount of seeds into the lid and choosing them horizontally, select the size of the groove into which the desired amount is inserted.

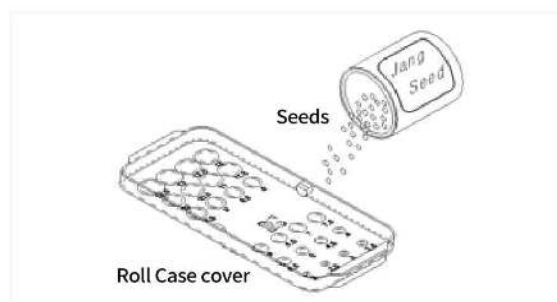
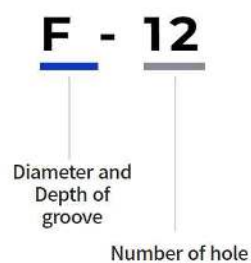

5. Control of each part

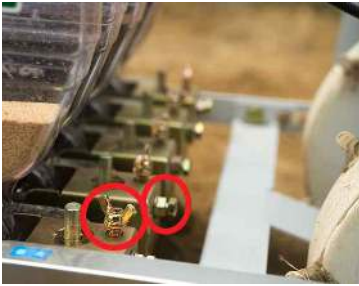

- ① The seeding depth is adjusted up to 30mm at 10mm intervals with the plow fixing bolt.
- ② To adjust the hopper block, loosen the butterfly bolt, move the hopper block left/right, and then fix it again.
- ③ For adjustment of the spot seeding interval (Intra row), please refer to the spot seeding spacing standard table.

6. Maintenance Inspection

- ① After completing the work, completely remove the seeds from the hopper and wash them.
- ② Please remove any unnecessary foreign substances attached during work.

7. Seeding Roll List

Seeding roll selection method

Seed	large			medium			small			Intrarow spacing (Front/Rear spacing) (cm)
	Seeding roll name	Discharge / Shape	Outer diameter (φ) / Depth (dp,mm)	Seeding roll name	Discharge / Shape	Outer diameter (φ) / Depth (dp,mm)	Seeding roll name	Discharge / Shape	Outer diameter (φ) / Depth (dp,mm)	
balloon flower	MJ-24	estimated 40EA / V Hole	φ6.5 / 3.5							2.5-6.5
Milk Vetch Root	MJ-12	5-6EA / V Hole	φ6.5 / 3.5	F-12	3-4EA / U Hole	φ5 / 2.5				5-13
DeoDeok	J-12	estimated 18EA / half moon groove(Hole)	φ12 / 12.4							5-13
Green Onion	MJ-12	4-5EA / V Hole	φ6.5 / 3.5	FJ-12	2-3EA / V Hole	φ6 / 3				5-13
Curled Mallow	YK-12	2-3EA / U Hole	φ3.5 / 2.3							5-13
Crown Daisy	MJ-12	estimated 8EA / V Hole	φ6.5 / 3.5							5-13
Spinach	MJ-12	1EA / V Hole	φ6.5 / 3.5	F-12	1EA / U Hole	φ5 / 2.5				5-13
Young Radish	MJ-12	1EA / V Hole	φ6.5 / 3.5	FJ-12	1EA / V Hole	φ6 / 3				5-13
Lettuce	XY-12	4-8EA / + Hole	φ2.5 / 1.2							5-13
Winter-Grown Cabbage	TL-12 (Winter-Grown Cabbage)	1EA / V Hole	φ5 / 2	YJ-12 (Winter-grown cabbage)	1EA / V Hole	φ5 / 1.8				5-13
Chives	A-6	estimated 5EA / U Hole	φ14 / 6	C-6	estimated 30EA / U Hole	φ11 / 5.5	D-6	estimated 20EA / U Hole	φ10 / 5	11-26
Sesame	F-8	6-7EA / U Hole	φ5 / 2.5	X-8	3-4EA / U Hole	φ4 / 2				8-19
Perilla	F-8	3-4EA / U Hole	φ5 / 2.5							8-19
Carrot	MM-12	6-7EA / U Hole	φ6 / 2.5	M-12	3-4EA / U Hole	φ5 / 2				5-13
Gimjang Cabbage	X-3	3-4EA / U Hole	φ4 / 2							21-51
Gimjang Radish	Q-4	6-7EA / U Hole	φ8 / 3	L-4	2-3EA / U Hole	φ7 / 2.5				16-38
Indian Mustard / Bok choy, Vitamin	YYJ-12	1EA / V Hole	φ3 / 1.7mm							5-13
Young Radish	L-12	2-3EA / U Hole	φ7 / 2.5mm							5-13
Onion (Direct Seeding)	F-24	2-3EA / U Hole	φ5 / 2.5mm							2.5-6.5
Onion(Nursery Plant)	E1-72	2-3EA / U Hole	φ4.5 / 2.5mm							0.6-1.6
Korean Ginseng	6L-6	1EA / V Hole	φ9.5 / 6.5mm	5L-6	1EA / V Hole	φ9 / 6.5mm	4L-6	1EA / V Hole	φ8.5 / 6.5mm	11-26
Dong cho	YYJ-24	1EA / V Hole	φ3 / 1.7mm							2.5-6.5
Coriander	LJ-12	1-2EA / V Hole	φ7 / 3.7mm	MJ-12	1EA / V Hole	φ6.5 / 3.5mm				5-13
pickled radish	R-4	3-4EA / U Hole	φ9 / 3.5mm	Q-4	2-3EA / U Hole	φ8 / 3mm				16-38
Chamnamul	A-6	estimated 90EA / U Hole	φ14 / 6mm	AA-6	estimated 80EA / U Hole	φ12 / 6mm	C-6	estimated 60EA / U Hole	φ11 / 5.5mm	11-26
Green Young Radish	MJ-8	estimated 2-3EA / V Hole	φ6.5 / 3.5mm	FJ-8	1EA / V Hole	φ6 / 3mm				8-19

For information, the user can check the below web site.

http://www.jangauto.com/eng/sub.php?code=105&part=2&p_code=109

4 How to adjust the spot seeding spacing

1. Sprocket components based on spot seeding spacing

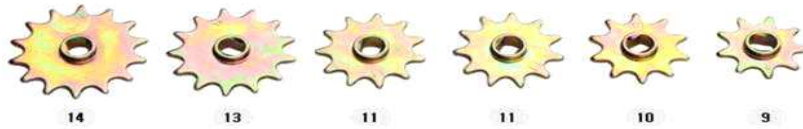

The seeding interval (Intra row) is determined by the combination of chain gear teeth (adjustable in 11 steps) and the number of holes in the seeding roller. The purchased product includes chain gears with teeth numbers of 9T, 10T, 11T (2 pieces), 13T, and 14T.

2. Spot seeding spacing standard table

Spot Seeding Spacing Standard Table

How to check the spot seeding criterion table

- ① Check the number of holes in the seeding roll/disc to be applied.
- ② Find the desired spot seeding spacing.
- ③ Check the number of teeth of the corresponding seeding roll/disc side and wheel side chain gear.

Spot Seeding Spacing Standard Table(cm)												
		Teeth number of Chain gear										
Seeding roll side		14	14	③ 13	13	11	11	10	11	10	10	9
Wheel side		9	10	10	11	10	11	11	13	13	14	14
Hole number of seeding roll	3 Holes	51	46	43	39	36	33	30	28	25	23	21
	4 Holes	38	35	32	29	27	25	23	21	19	18	16
	6 Holes	26	23	21	19	18	16	15	14	13	12	11
	① 8 Holes	19	17	② 16	15	14	13	12	11	10	9	8
	10 Holes	16	14	13	12	11	10	9	8	8	7	6
	12 Holes	13	12	11	10	9	8	7	7	6	6	5
	20 Holes	8	7	7	6	6	5	5	4	4	4	3
	30 Holes	5	5	4	4	4	3	3	3	3	2	2

← Standard →

▶ Depending on the soil quality or speed, the spacing may not be consistent.

3. Consumables

The following parts are consumables. Inspect before work, and replace if there are any abnormalities such as wear.



Brush



Guide plate

5 Seeder Operation Tips

1. Battery assembly and power connection

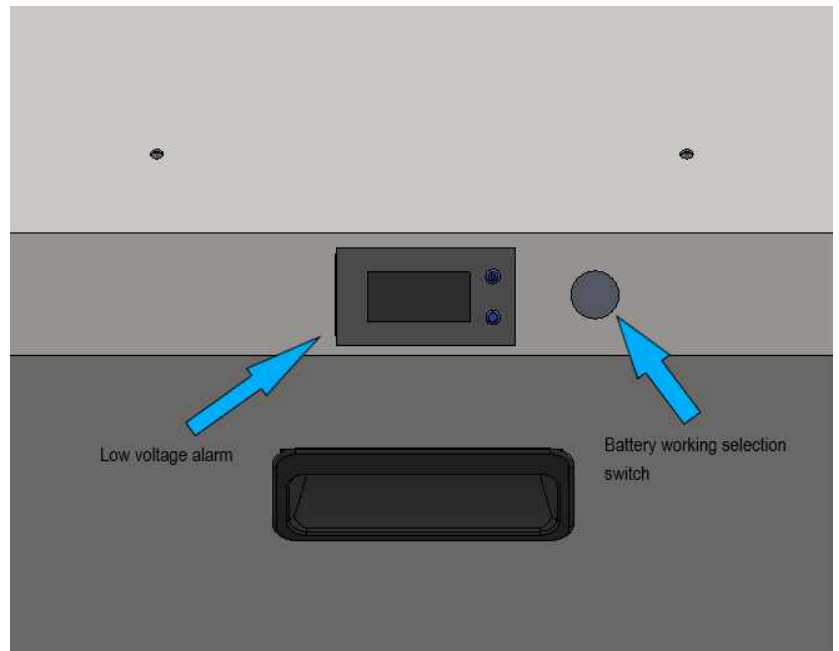

Speed Controller

- ▶ Open the case and match the battery adapter insertion part to the shape of the battery. 2pcs of batteries are composed as 1set and the 1set is only worked during seeding, NOT 3sets of batteries working at the same time.

Caution

: If the battery adapter and battery manufacturer do not match, insertion will not be possible, so do not force insertion.

- ▶ Turn the battery working selection switch toward the battery you want to select.
- ▶ Select the speed controller from 1 to 5, not stop.
- ▶ If the voltage level appears on the low voltage alarm and the driving roll operates, you can confirm that the power is connected.
- ▶ The recommended battery specification is 5ah for (18V or 20V).
- ▶ When the battery power reaches 0%, it cannot be operated manually, so the battery must be replaced when the low voltage alarm sounds.

2. Speed Controller Operation (5 Steps)



- ▶ If you turn the volume-type speed controller from left to right, the speed increases.
- ▶ Forward: Using this, the user drives according to the desired speed among 5 levels of speed control.
- ▶ Stop : Turn the speed controller from right to left to STOP to stop.
- ▶ Emergency **RED** button: When driving, if you want to stop in an emergency, press the red button on the left. If you want to drive again, turn to the right so that the pressed Emergency **RED** button moves up.

3. How to rotate the return point when sowing

- ▶ When sowing, stop the machine at the end of the return point using the speed controller, press the handle, lift the drive roller (front wheel), rotate about 130 degrees to the desired seeding section, then lift the handle and sow in the next seeding section with the pressure roll lifted. Operate the speed controller again to start seeding.
- ▶ When moving the seeder after sowing is finished, the hopper must be detached or stopped in operation to prevent seeds from being discharged. (Seeds are discharged as the drive roll rotates, so it must be stopped using the speed controller and rotated only with the suppression roll.)

4. Tips for Moving

- ① Installation and removal of auxiliary wheels
 - ▶ Lift the handle and keep the suppression roll lifted.
 - ▶ Insert and install the axes of the auxiliary wheels into the grooves of the auxiliary wheel brackets on the left and right sides, respectively. (When sowing seeds, detach and use the auxiliary wheels.)
- ② Movement (forward, backward, left and right direction control)
 - ▶ Lift the drive roll (front wheel) and move only with the moving wheels. (The drive roll does not move unless the speed controller is activated.)

6 Worker Regulation

1. Worker's Health Care

- ① Farming workers need a enough rest and regularly take health check. If the workers have disease, they should see a doctor or professional health counselor and carefully make working plan not to lead to accidents.
- ② Workers should work for less than 8 hours in a day and take rest every 2hours not to take fatigue.
- ③ Workers should have stretching before and after work. Workers should work without overload in accordance with workers' condition and weather's condition. If many people work together, they should discuss how to work in advance.
- ④ If working process is not smooth because of weather or state of paved road, do not do it to excess. It can cause accident. Make working plan with taking time.

2. Restriction on Worker

Following workers must not use agricultural machines and working on the high place and not order.

- ① Drunken workers.
- ② Workers who have problems to work by taking medicine.
- ③ Workers who is difficult to work because of disease, wound, fatigue etc.
- ④ Workers who is in pregnancy or can be affected to pregnancy or giving birth.
- ⑤ Underage
- ⑥ Learners(Except with an expert)

3. Safety label

- ① Do not take off the safety labels on the machine.
- ② Do not touch parts rotating or moving.
- ③ Please seeding in straight.
- ④ Do not arrow to approach near working area. Especially keep an eye on children.
- ⑤ Do not go under the machine or not put your foot under wheels.
- ⑥ Do not take off the covers

4. Inspection during work

- ① When inspecting the work machine, do so after confirming that the power has been cut off.
- ② Work while checking the consumption status of the seed container.
- ③ The motor is high temperature, so be careful of burns.
- ④ Properly manage and use tools required for inspection and maintenance properly.
- ⑤ Be sure to reinstall the safety cover that was removed after inspection.

7 Clothes, Protect equipment wearing and Protection device

1. Clothes and protect equipment

- ① Wears proper clothes and hat and protect equipment not to take accident with agricultural machines such as hair or clothes are rolled.
- ② It is very dangerous action to wear loose clothes or gloves to repair the machines.
- ③ Put on safety shoes which is proper your feet and get slip-resistant.
- ④ Long hair can easily be rolled into the rotating machine so tie the long hair or put it in the hat.
- ⑤ Do not wear valuables while working.

2. Improvement of working environment

- ① Workers check working environment or dangerous area in ordinary day and work in safe and effective way by reviewing working way or marking the dangerous area.
- ② Agricultural machines are often rolled over at waterway or ditch been washed away, improve working environment which can often happen accident such as a corner of blind spot, sharp curve, narrow bridge, slippery road.
- ③ If you found hazards, immediately improve the hazards. To reduce the hazards being dotted, workers have to respect following Agricultural machine driver must take enough space to rotate in safety not to close to the waterway or the ditch.
- ④ Cuts grass around edge of farm road which has been hazard so make sure to see ditch or farm road.
- ⑤ Gets rid of branches, stumps and other things to see clearly driving.
- ⑥ When working in dangerous, reduce worker's worries and work with a assistant who let the worker know dangerous state. Not to work alone. If you have no choice to work alone, must inform your family where and what you work. It helps to find you as soon as possible when you are in troubles.
- ⑦ When commission, the consignor must inform the assignee hazards and dangerous area before starting work.

8 Compliance with the scope of machine and parts after operating (Scope of application and handling precautions)

1. Application Range

- ① It is applied to a battery-type seeder that can be controlled and operated by the operator.

2. Keeping and reading the instruction

- ① Read the instruction manual carefully and become familiar with the functions, precautions for use, use of safety devices, and ways to avoid danger.
- ② Store the instruction manual in a certain storage location so that it can be taken out and read at any time when necessary.
- ③ For long-term storage, remove the battery.
- ④ Clean mud, dust, etc. on agricultural machinery to prevent rust and corrosion, remove moisture with a dry cloth, and then wipe with a cloth soaked in oil.
- ⑤ Apply grease to prevent rust on chains, wires, rotating parts, etc., and paint the car body where the paint has peeled off.
- ⑥ Inspect each part for wiring, loosened bolts and nuts, etc., and immediately repair any defective parts.
- ⑦ Agricultural machinery should be stored indoors as dry as possible. If indoor planting is difficult, cover and store on a flat surface to avoid sunlight, rain, and snow.

3. Prohibition of modification and use of station for other purpose

- ① Do not use for any purpose other than its original purpose.
- ② Do not remodel. In particular, do not remove the safety device.

9] Precautions of third parties

1. Third party precautions

- ① Due to the nature of agricultural machinery vehicles, the noise level is high, making it difficult for drivers to perceive the surrounding environment. You should always check your surroundings and get into the habit of walking slowly.
- ② Because there are many trees or grass on the road, agricultural vehicles that were hidden from view may suddenly appear in front of you and cause an accident. Therefore, especially for children, active protection and safety education should be provided to prevent accidents due to contact with parked agricultural machinery.
- ③ Consideration of women, young people, and the elderly Pregnant women and young people are not asked to do high-risk work or handle chemicals, such as handling heavy objects, working at heights, or working in environments with high vibration.
Additionally, pregnant women and minors are not asked to work late at night.
- ④ Comprehensive safety education, including daily health care, should be provided to the elderly, taking into account the decline in mental and physical functions, such as loss of agility, as one ages. Additionally, if possible, encourage elderly people to perform agricultural work through consignment rather than doing it themselves. Work sites should be made as safe and comfortable as possible for anyone to use, and the use of elderly people should be taken into consideration when selecting agricultural machinery.

2. Consideration for surrounding environment

- ① Consideration for those around you
When engaging in agricultural work, pay attention to ensuring sufficient safety, taking into account the risk to other workers and people around you. In particular, if there are children nearby, it is necessary to give sufficient precautions in advance to ensure that they do not approach agricultural machinery in operation.
- ② Consideration of surrounding environment, etc.
Necessary measures must be taken by carefully considering the selection of work machinery and weather conditions to prevent noise, vibration, dust, etc. generated during work using agricultural machinery from affecting nearby residents or the environment.

10 Contents for material used, such as battery

1. Handling of agriculture machinery, etc.

① Required standards

All farm equipment must be managed and stored cleanly by washing, disinfecting, etc. to prevent contamination with hazardous substances.

② Recommended standards

Records related to the use of farm equipment must be maintained.

All farm equipment must be stored in a place where it is easy to clean, maintain hygiene, and drain.

③ The battery must be removed and stored to prevent shortening of battery life.

④ The motor driver is not completely waterproof, so it must be stored indoors after sowing.

11 User's guide

→ For your safety, please read this in advance.

1) Matters before use

A) Matters related to machine assembly

: When connecting the handle and main body, connect the jack as well.

B) Matters related to the worker's health status and worker restrictions

: If you have health problems, avoid sowing outdoors for long periods of time.

C) Matters related to clothing, wearing protective cloth, protective devices, etc.

: Do not open the battery case too forcefully.



D) Precautions regarding third parties, especially children

: A guardian must always be with the child when driving.

F) Matters related to machine transportation

: When loading or unloading trucks, etc., use transport wheels and a ladder.

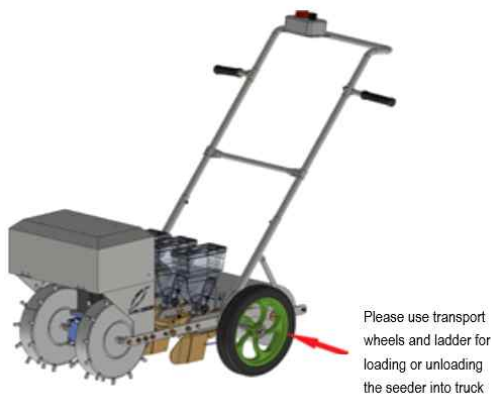

G) Matters related to the markings specified on the main body, etc.

: Since it is self-propelled, accidents may occur due to constriction, so the driver must always look ahead.

2) Matters related to inspection before working

A) Inspection preparation and methods required for safe use

: Because it is electric, wiring, etc. may be exposed to water or the battery may not be charged. Please check if it worked.

3) Matters regarding caution during work

A) Matters regarding the correct use method and posture of the machine

: Adjust the handle to suit the height of the worker who will be using it for a long time.

B) Matters that call attention to people around other than the worker

: Do not allow people to pass along the driving path of the seeder.

4) Matters related to after use

A) Matters regarding major inspection points and inspection methods

- Check if the fuse is normal.

- Check if there are any stones or foreign substances stuck in the protrusions of the driving roller.

B) Matters related to treatment and disposal of used materials, etc.

- Remove used batteries and store them indoors in a cool place.

- Please store used seeder indoors.

C) Precautions for long-term storage

- Please store it indoors as it is not completely waterproof.

5) Other necessary information

A) Matters related to inspection and repair that workers must not perform

- When checking the wiring of the motor driver, please contact our head office.
If the wiring is twisted, it won't work.

B) Matters related to contact and inquiry about the machine

(Product name, type, company name, address, phone number)

- Product name: Battery-type leafy vegetable seeder, 3rows

- Model Name : JPEV-3

- Company name: Jang Automation Co., Ltd.

Address: 2004, Nangseong-myeon, Danjae-ro, Sangdang-gu, Cheongju-si, Korea

Phone number: 82-(0)43-298-0076

12. Parts List

1. Hopper Assembly

01. 호퍼부

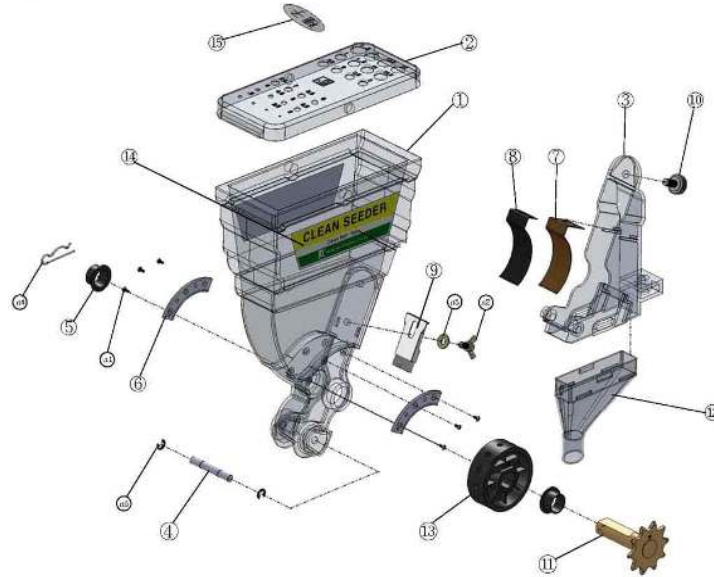

NO	Drawing Number	Description of Goods	Quantity(pc)
1	JP100-11-0101	Hopper	3
2	JP100-11-0102	Hopper Cover	3
3	JP100-11-0103	Hopper Case	3
4	JP100-11-0104	Hopper Case Connection Pin	3
5	JP100-11-0105	Oilless Bushing	6
6	JP100-11-0106	Roll Rib	6
7	JP100-11-0107	Guide Plate	3
8	JP100-11-0108	Cloth	3
9	JP100-11-0109	Brush	3
10	JP100-11-0110	Knob	3
11	JP100-11-0111	Hopper Sprocket(10T)	3
12	JP100-11-0112	Seed Guide Sticker	3
13	JP100-11-0113	Seeding Roller	3
14	JP100-11-0114	Brand Name Plate	6
15	JP100-11-0115	Seed Sticker	3
N1		SUSBolt(3mm)	18
N2		Butterfly bolt(5mm)	3
N3		Flat washer(5mm)	3
N4		R Pin	3
N5		Stop Ring	6

2. Hopper Block Assembly

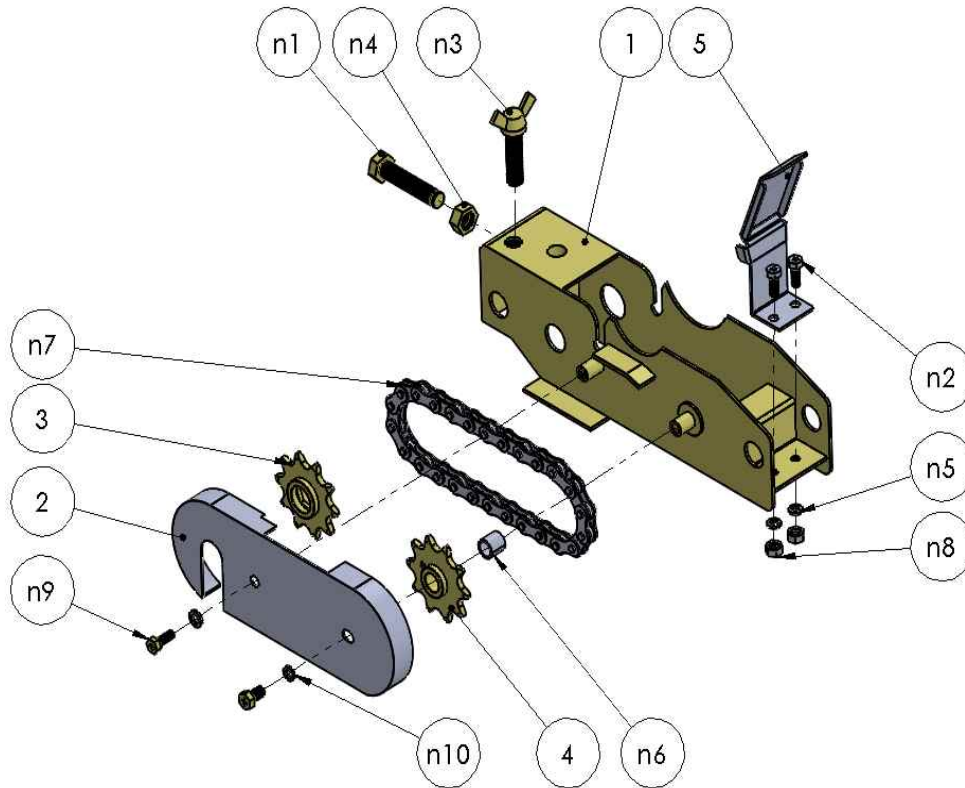

NO	Drawing Number	Description of Goods	Q;ty(pc)
0	JP100-02-000	Hopper Block	3
1	JP100-02-001	Hopper Block Combination	3
2	JP100-02-002	Chain Cover	3
3	JP100-02-003	Hex Sprocket(10T)	3
4	JP100-02-004	Idle Sprocket(10T)	3
5	JP001-02-005-NZ	Grip	3
n1	NO1-03-080040-1	Hex Bolt	3
n2	NO1-04-050010-1	Cross Groove Hex Bolt	6
n3	NO1-02-080030-1	Butterfly bolt	3
n4	NO2-01-080000-1	Hex Nut	3
n5	N06-03-040000-1	Spring Washer	6
n6	NO5-01-080010-1	Bushing	3
n7	N07-01-000058-4	Chain	3
n8	N02-01-040000-1	Hex Nut	6
n9	N01-04-040010-2	Corss Groove Hex Bolt	6
n10	N06-03-050000-1	Spring Washer	6

3. Plow Assembly

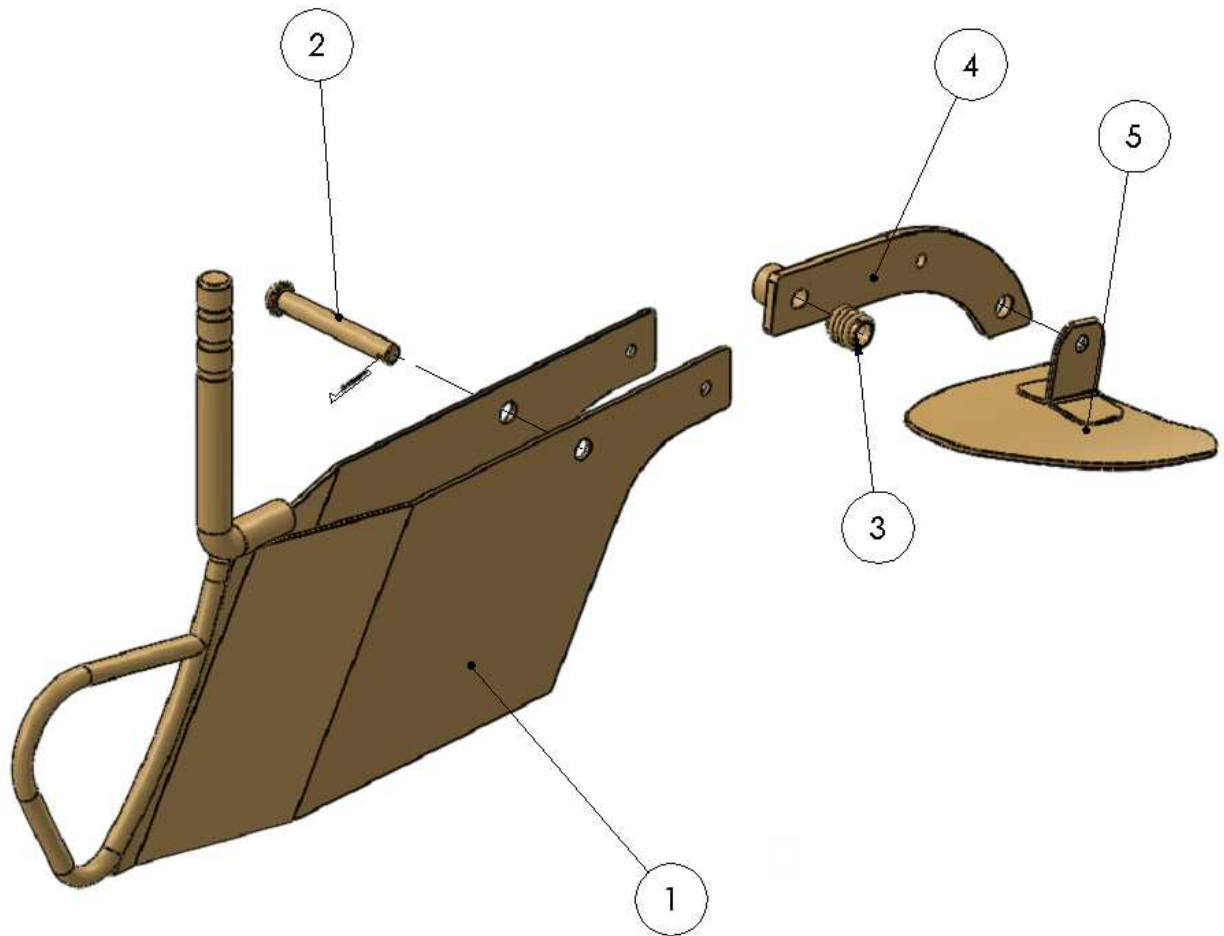

NO	Drawing Number	Description of Goods	Quantity(pc)
1	JP100-11-0301	Stanard Plow	3
2	JP100-11-0302	Plow Head Pin	3
3	JP100-11-0303	Plow Spring	3
4	JP100-11-0304	Plow Lever	3
5	JP100-11-0305	Soil Covering wing(70mm)	3

4. Driving & Suppressing Roller

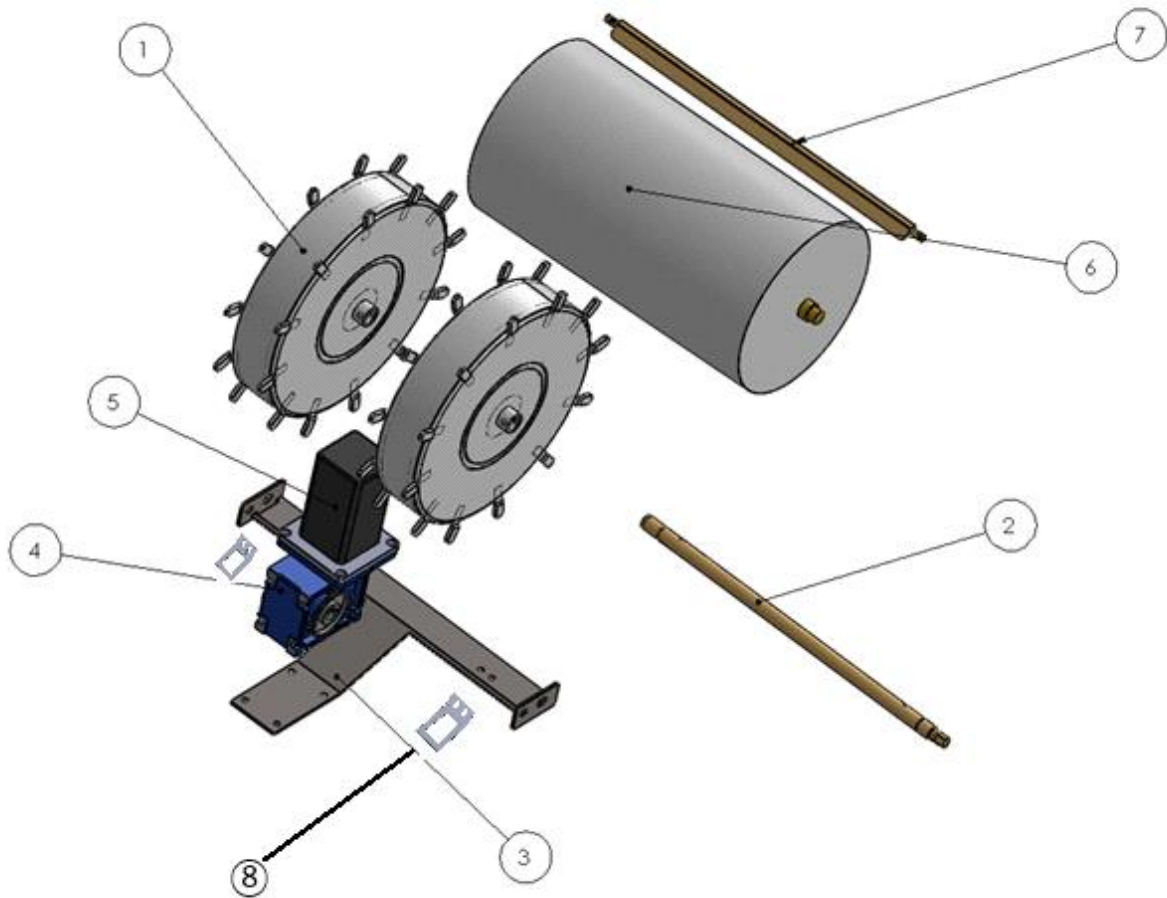

NO	Drawing Number	Description of Goods	Quantity(pc)
1	JPEV3-03-001	Driving Roller	2
2	JPEV3-03-001	Driving Roller Shaft	1
3	JPEV3-03-001	Inter row mark	1
4	JPEV3-03-001	Reducer	1
5	JPEV3-03-001	Motor	1
6	JPEV3-03-001	Suppressing Roller	1
7	JPEV3-03-001	Suppressing Roller Scraper	1
8	JPEV3-03-001	Driving Roller Scraper	2

5. Chain Case Assembly

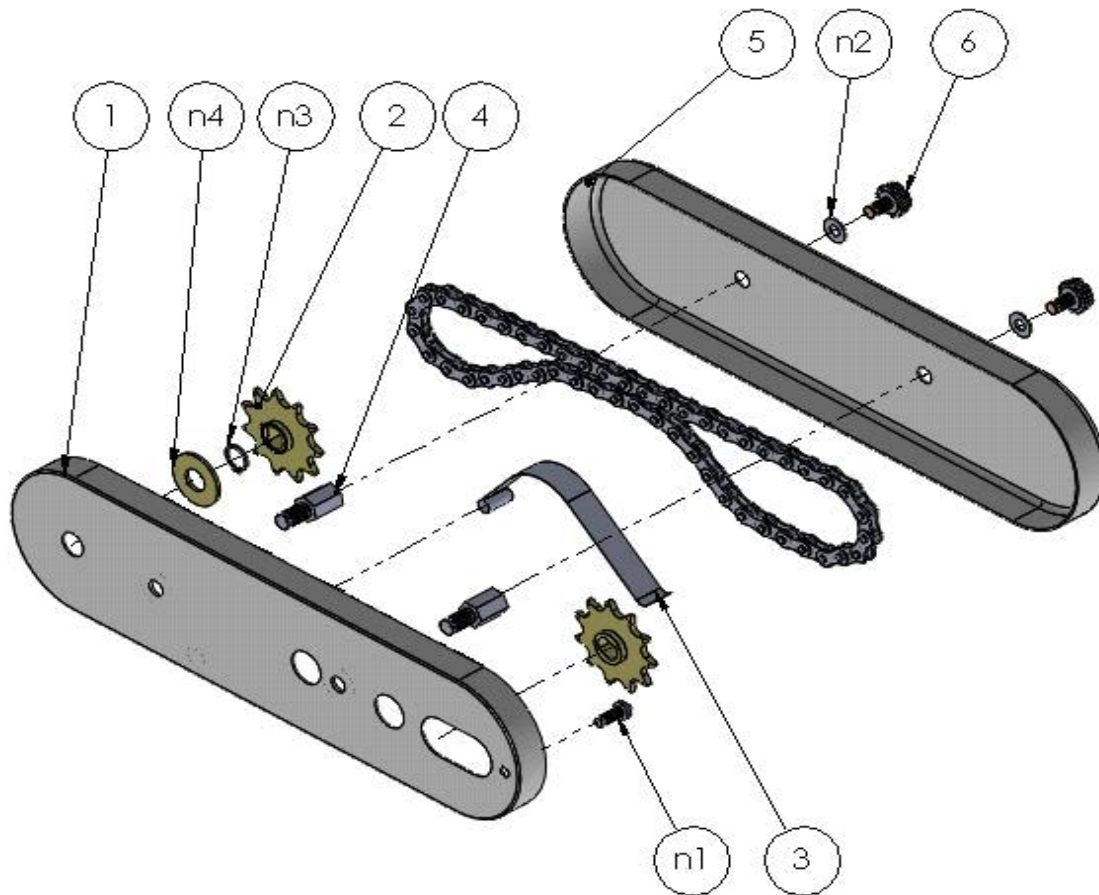

NO	Drawing Number	Description of Goods	Q'ty(pc)	Remark
1	JP001-05-001	Chain Case(Inner)	1	
2	JP001-05-002	Sprocket 11T	2	
3	JP001-05-003	Chain Tension Spring	1	
4	JP001-05-004	Chain Case fixing shaft	2	
5	JP001-05-005	Chain Case (Outer)	1	
6	JP001-05-006	Knob	2	
7	JP001-05-007	Type Name Plate	1	
8	JP001-05-008	Spot Seeding spacing Chart	1	
n1	N01-01-050016-1	Round Head Cross Bolt	1	
n2	NO6-01-06000K-1	Flat Washer	2	
n3	NO3-02-120000-1	Snap Ring for shaft	1	
n4	NO6-01-12000B-1	Flat Washer	1	

6. Frame Assembly

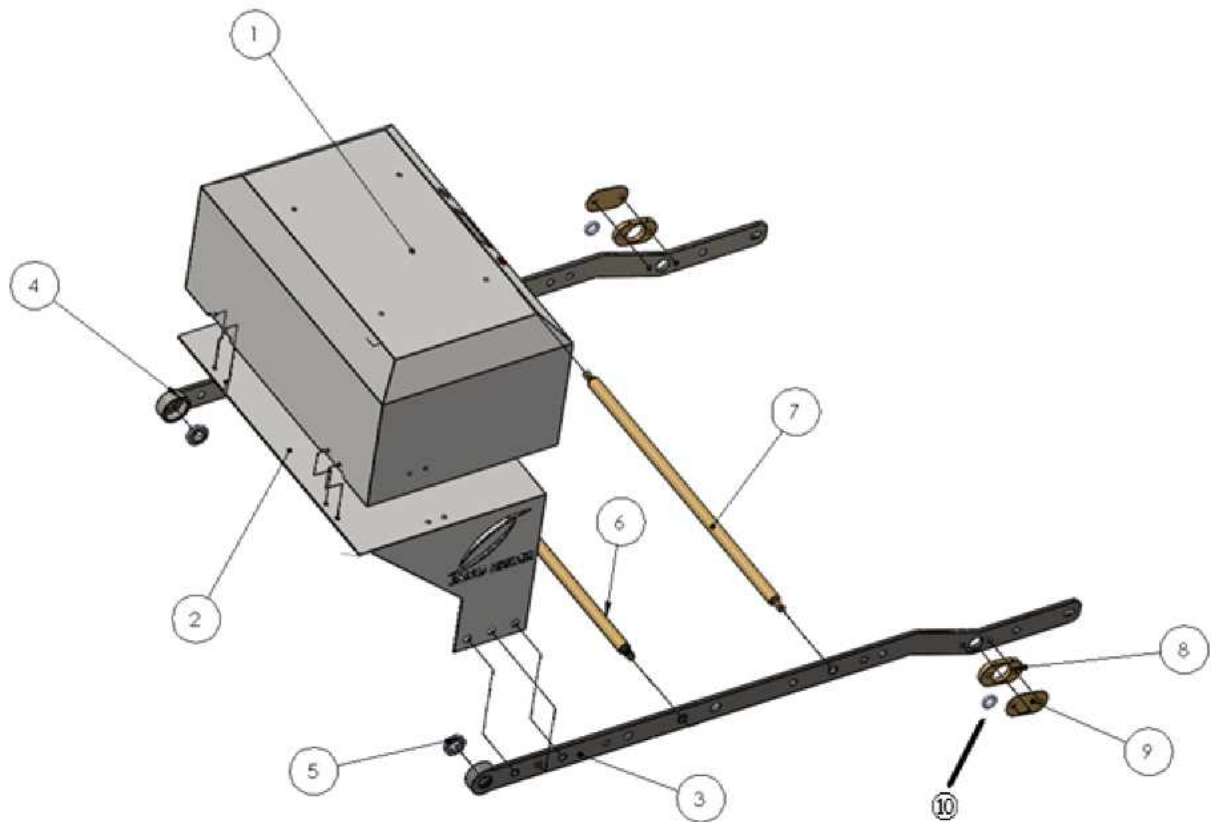

NO	Drawing Number	Description of Goods	Q'ty(pc)
1	JPEV3-06-001	Battery Panel Case	1
2	JPEV3-06-002	Battery Panel Fixed Bar	1
3	JPEV3-06-003	Main Side Frame(Left)	1
4	JPEV3-06-004	Main Side Frame(Right)	1
5	JPEV3-06-005	6902DD Bearing	1
6	JPEV3-06-006	Guide Shaft (Front)	1
7	JPEV3-06-007	Guide Shaft (Rear)	1
8	JPEV3-06-008	Suppressing roller Bearing Sprocket	2
9	JPEV3-06-009	Suppressing roller Bearing Sprocket Plate	2
10	JPEV3-06-010	6802DD Bearing	2

7. Handle Assembly

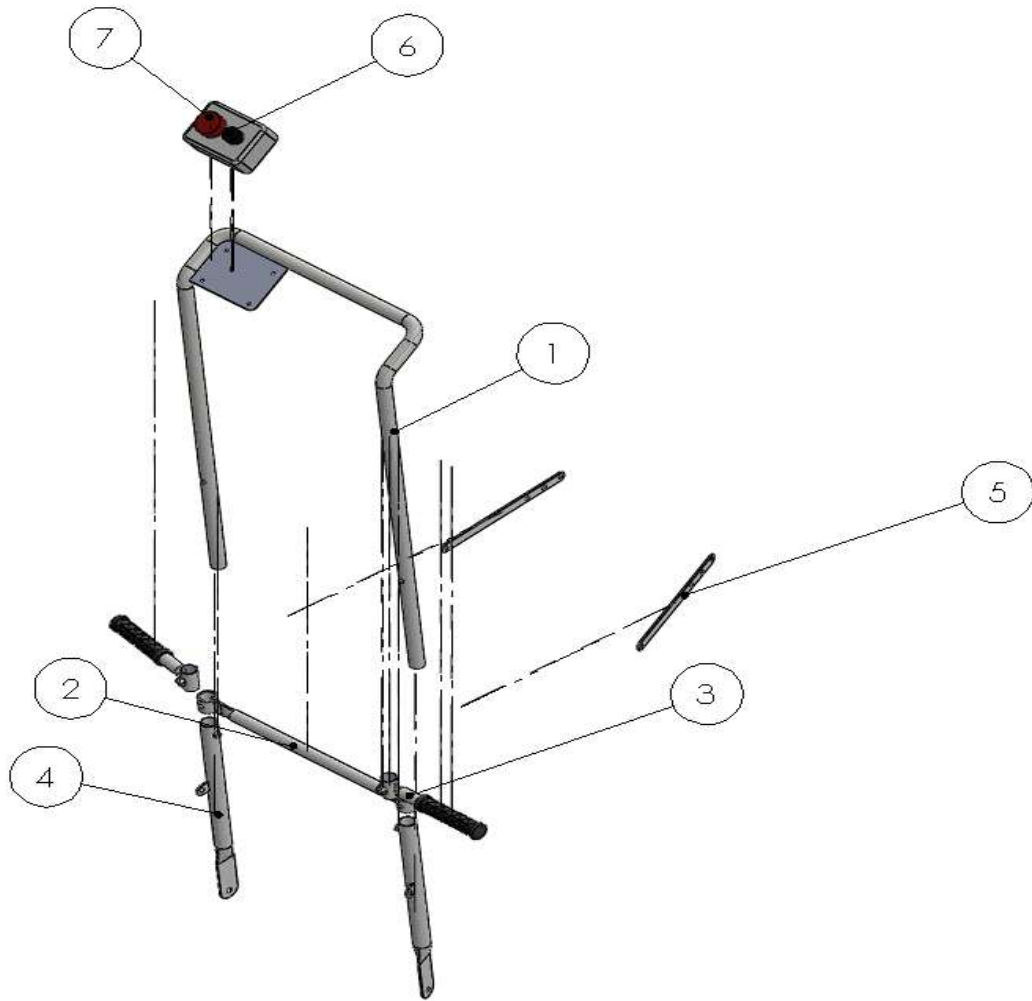

NO	Drawing Number	Description of Goods	Quantity(pc)
1	JPEV3-07-001	Handle (C)	1
2	JPEV3-07-002	Handle C Reinforce Bar	1
3	JPEV3-07-003	Side Handle	2
4	JPEV3-07-004	Handle (B)	2
5	JPEV3-07-005	Handle B Support	2
6	JPEV3-07-006	Speed Controller	1
7	JPEV3-07-007	Emergency Button	1

8. Transfer Device

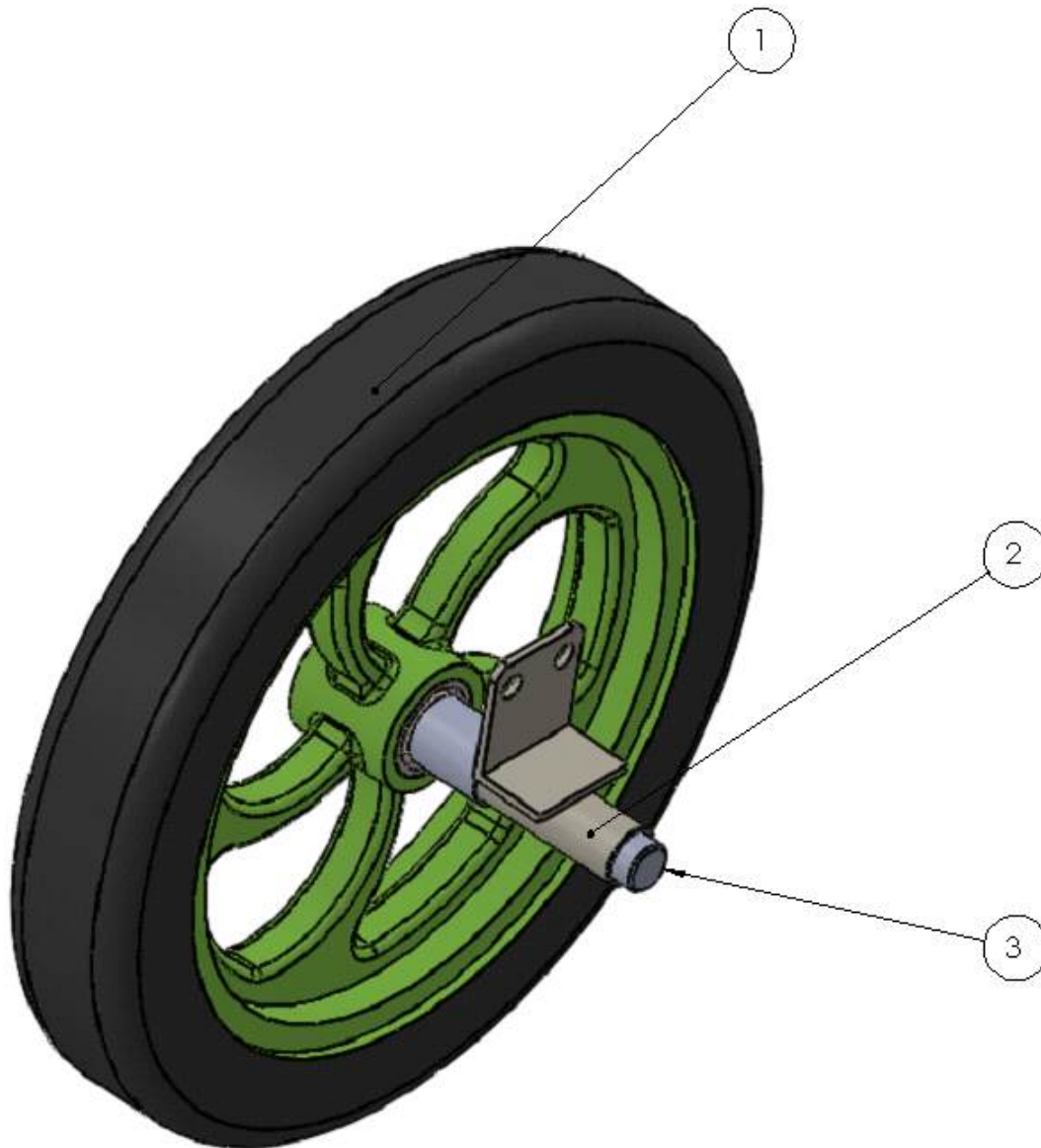

NO	Drawing Number	Description of Goods	Q'ty(pc)
1	JPEV3-08-001	Transport Wheels	2
2	JPEV3-08-002	Transport Wheels Bracket	2
3	JPEV3-08-003	Transport Wheels Bracket Shaft	2